

NEXUS[®]

HU SERIES

HIGH EFFICIENCY

GAS-FIRED, UNIT HEATER

REPLACEMENT PARTS CATALOG

INDEX	PAGE
Warranty Information - Return Goods	2
HU Series Unit Number Description	3
HU Series 050-400MBH Replacement Part Diagrams	4-6
HU Series 050-400MBH Replacement Parts	7-10
Gas Conversion Kits & Transformers	11
Field Installed Accessories & Miscellaneous	12

IMPORTANT

When ordering replacement parts,
please specify model and serial number.

IMPORTANT WARRANTY INFORMATION

If you are ordering a replacement part for a unit which you believe to be under warranty, the process is as follows:

- Provide Sterling with a replacement purchase order for the item along with the model and serial number of the unit which experienced failure.
- Complete a Return Goods Authorization (R.G.A.) request form and submit with replacement purchase order. Complete description of failure is required; “defective” is not acceptable.
- Your replacement purchase order will be entered and an R.G.A., with instructions on how and where to send the defective parts, will be emailed to the email address listed on the R.G.A. request form submitted.
- Your replacement parts order will ship and invoice. The invoice will list the R.G.A number and state: “an R.G.A. has been issued.”
- Returned goods must ship back within 30 days from date of R.G.A. If we do not receive the parts within 30 days, the RGA will be voided. Parts returned and found to be valid under warranty will be credited for parts only. If our inspection reveals that the parts returned are in a non-warranty condition, no credit will be issued. Freight is not covered under warranty.

In order to ensure the orderly processing of your warranty claim, it is **MANDATORY** that certain paper work accompany any and all goods returned to Sterling. It is also mandatory that goods be sent to the proper location.

In order to ensure proper handling of these goods, we insist that under all circumstances we must formally authorize the return of material to our various facilities. Any material returned without authorization will not be accepted.

In order to ensure that your properly authorized returns are accepted at our plant, we ask that you clearly mark any and all shipping papers with an R.G.A. number; we will not accept shipments that do not clearly show R.G.A. number on the outside of the box or crate!

**All returns to be shipped Freight Prepaid.
Collect Shipments will not be accepted.**

CONSULT OUR CUSTOMER SERVICE DEPT. FOR ANY REPLACEMENT PARTS NOT LISTED IN THIS PUBLICATION. LIMITED AVAILABILITY ON CERTAIN OBSOLETE EQUIPMENT.

TEL. 413-564-5540 FAX# 413-562-5311
EMAIL: custservice@sterlinghvac.com

NEXUS - HU SERIES

HIGH EFFICIENCY GAS-FIRED UNIT HEATER

UNIT NUMBER DESCRIPTION

Digit	N	X	X	X		1	2	3	4	5	6	7	8	9	10	11	12	13	14	15	+
Item	Prefix					UT		CA		FT	FM	GT	AL	GC	SV	MT	MS	DL	AS		

(Internal Use Only)

1,2 - Unit Type [UT]
HU - High Efficiency Unit Heater

3,4,5 - Capacity [CA]
050 - 50,000 BTU/HR
100 - 100,000 BTU/HR
150 - 150,000 BTU/HR
200 - 200,000 BTU/HR
300 - 300,000 BTU/HR
400 - 400,000 BTU/HR

6 - Furnace Type [FT]
A - Right Side Access

7 - Heat Exchanger (Furnace) Material [FM]
1 - Stainless Steel Tubes with Aluminum and Brass Fins
Note: Stainless Steel Flue Collector is standard.

8 - Gas Type [GT]
N - Natural Gas
P - Propane Gas (LP)

9 - Altitude [AL]
S - 0-11,999 ft.
Note: Installations over 2,000 ft. require gas input deration in the field. Refer to unit installation instructions.

10 - Direct Spark Gas Control [GC]
1 - Modulating w/Outside Air Reset (Master)
2 - Modulating w/Outside Air Reset (Network)
3 - Modulating w/Indoor Air Reset
4 - Modulating w/2-10 VDC/4-20 mA Input
5 - Modulating w/Room Sensing
6 - Two Stage

11 - Supply Voltage [SV]
1 - 115/1/60 **5** - 230/3/60
2 - 208/1/60 **6** - 460/3/60
3 - 230/1/60 **7** - 575/3/60
4 - 208/3/60 **Z** - Special
Note: Supply Voltage [SV] 2-7 include field mounted step down transformer.

12 - Motor Type [MT]
1 - Open Drip Proof (Standard)

13 - Blower Motor Sizes [MS]
0 - Not applicable

14 - Design Level [DL]
B - Second design level

15+ - Accessories [AS]

†FIELD INSTALLED (AS-_____)
†All Field Installed Accessories are to be entered as a separate line item using the catalog number which utilizes "11AS" as a prefix. i.e: G3 becomes 11AS-G3

A7 - High Pressure Regulator
A7-1/2-1 - Regulator for PSI range 0.5-10
A7-3/8-1 - Regulator for PSI range 10-20
A7-5/16-1 - Regulator for PSI range 20-35

E9 - Condensate Neutralizer (Inline)
EW - Condensate Neutralizer (Wall Mounted)

G1 - 1-Stage Mercury Free Thermostat (Round)
G2 - 1-Stage Mercury Free Thermostat w/Guard Kit
G3 - 1-Stage Mercury Free Thermostat/Fan Switch
G5 - 2-Stage Mercury Free Thermostat w/Fan Switch
G6 - Locking Thermostat Cover
G9 - 1-Stage Mercury Free Heating Only Thermostat
GW - WiFi Thermostat TH8321WF1001/u

H9 - Stratification Sensor

K8 - Condensate Pump
K9 - Condensate Pump Shelf

Y2 - 2" PVC Concentric Vent Kit (50-150 MBH)
Y3 - 3" PVC Concentric Vent Kit (200 MBH)
Y4 - 4" PVC Concentric Vent Kit (300-400 MBH)

HU SERIES 050-400 MBH REPLACEMENT PARTS

Figure 1 - Exploded View, Whole Unit

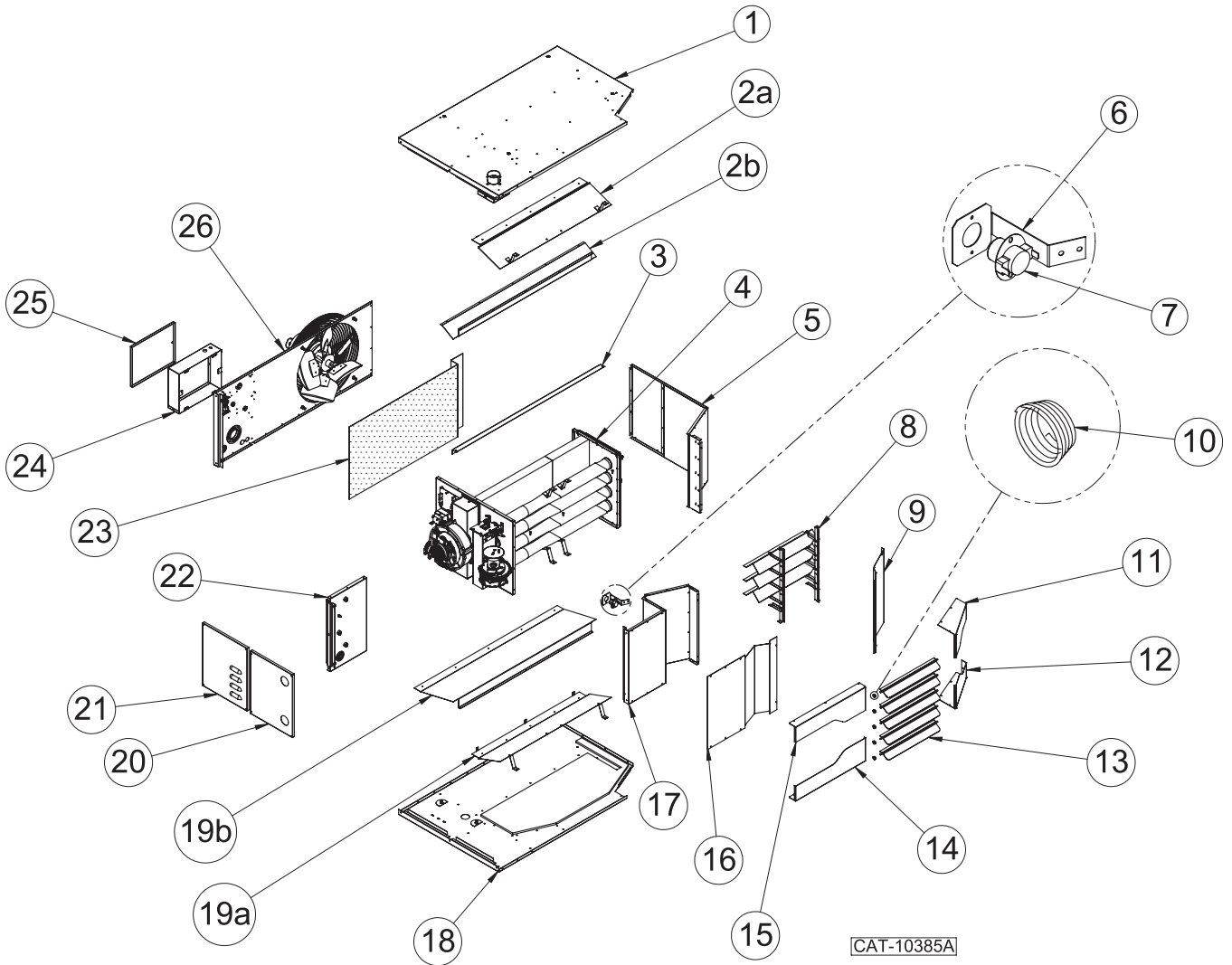

HU SERIES 050-400 MBH REPLACEMENT PARTS

Figure 4 - Vestibule Panel/Heat Exchanger Assembly

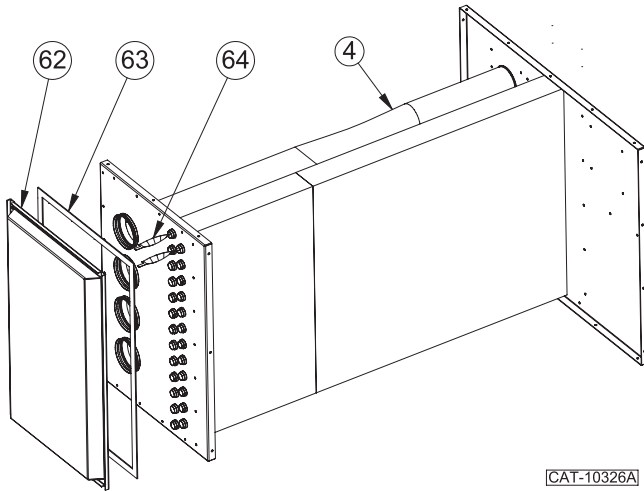

Figure 7 - Filter Box Assembly, Size 050

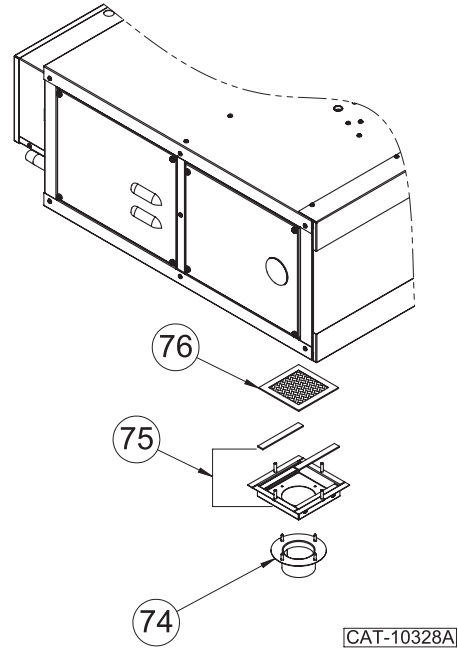

Figure 5 - Control Box Components

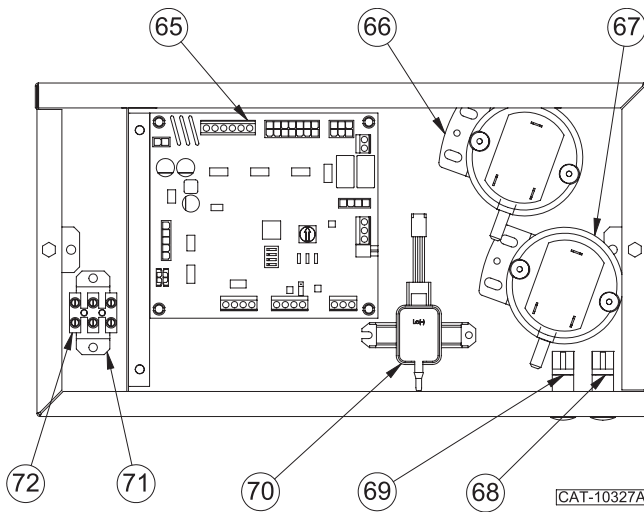

Figure 8 - Filter Box Assembly, Sizes 100-400

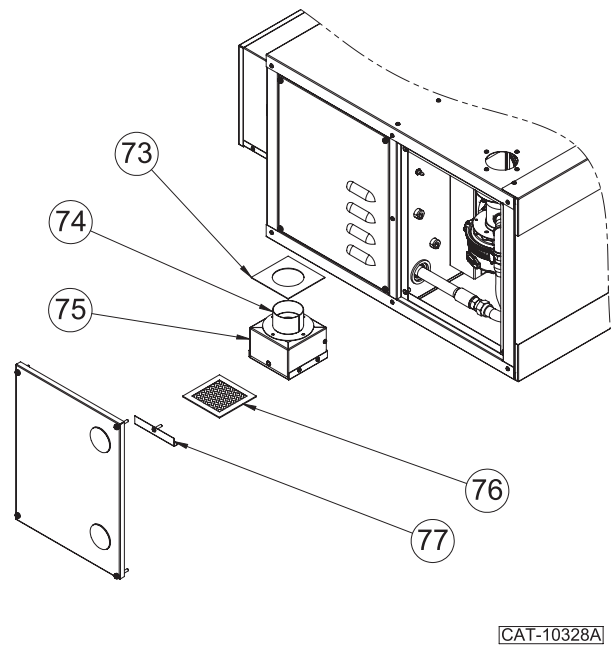
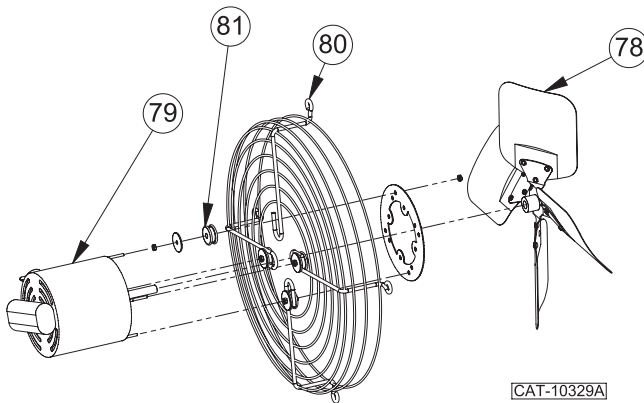

Figure 6 - Propeller Motor/Fan Assembly



HU SERIES 050-150 MBH REPLACEMENT PARTS

ITEM NO.	UNIT CAPACITY (MBH)	PART NO.		
		50	100	150
1	Top Jacket Panel w/ Insulation	11251R09998-050	11251R09998-100	11251R09998-150
2a, 2b	Top Panel Block-Off	11507R10015-050	11507R09738-100	11507R10015-15T
3	Heat Exchanger Block-Off [Qty. Req'd per Capacity]	11507R10126-050	N/A	11507R10126-000
4	Vestibule Panel/Heat Exchanger Assembly ¹	11501R09651-050	11501R09651-100	11501R09651-150
5	Left Side Jacket Panel w/ Insulation	11251R10009-050	11251R10009-100	11251R10009-200
6	High Limit Switch Bracket [Qty. Req'd per Capacity]	11252R09984-000 [2]	11252R09984-000	11252R09984-000 [2]
	Left High Limit Switch Bracket		N/A	
	Right High Limit Switch Bracket		N/A	
7	High Limit Switch [Qty. Req'd per Capacity]	11J11R09594-001 [2]	11J11R09594-001	11J11R09594-001 [2]
8	Heat Exchanger Baffle Assembly	11507R09993-100	11507R09659-100	N/A
9	Inner Left Façade Panel (Black)	11251R09732-050	11251R09732-100	
10	Louver Spring [Qty. Req'd per Capacity]	11J26R01960 [4]	11J26R01960 [5]	
11	Top Left Façade Panel	11251R09736-05T	11251R09736-10T	
12	Bottom Left Façade Panel	11251R09736-05B	11251R09736-10B	
13	Louvers [Qty. Req'd per Capacity]	11257R10063-100 [4]	11257R10063-100 [5]	11257R10063-200 [5]
14	Bottom Right Façade Panel	11251R09734-05B	11251R09734-10B	11251R09734-20B
15	Top Right Façade Panel	11251R09734-05T	11251R09734-10T	11251R09734-20T
16	Inner Right Façade Panel (Black)	11251R09731-050	11251R09731-100	11251R09731-200
17	Right Front Jacket Panel w/ Insulation	11251R10010-050	11251R10010-100	11251R10010-200
18	Bottom Jacket Panel w/ Insulation	11251R09999-050	11251R09999-100	11251R09999-150
19a, 19b	Bottom Panel Block-Off	11507R10015-050	11507R09738-100	11507R10015-15B
20	Burner Access Panel	11258R09997-050	11258R09997-100	11258R09997-200
21	Power Venter (Drafter) Access Panel	11251R09664-050	11258R09717-100	11258R09717-200
22	Partition Panel	11251R09689-050	11251R09689-100	11251R09689-200
23	Heat Exchanger Screen	11501R09987-050	11501R09987-100	11501R09987-200
24	Control Box Base (Wrapper)	11257R10336-001	11257R10336-002	
25	Control Box Access Panel	11251R09991-001	11251R09991-000	
26	Rear Jacket Panel	11251R09996-050	11251R09996-100	11251R09996-200
27	Manual Rollout Safety Switch	11J11R09595-001		
28	Manual Rollout Safety Switch Bracket	11252R09995-000		11252R09995-150
29	Spark Ignitor Bracket [Qty. Req'd per Capacity]	N/A	11252R09715-000	11252R09715-000 [2]
30	Spark Ignitor [Qty. Req'd per Capacity]	11J38R06891-001		11J38R06891-001 [2]
31	Inlet Air Cover Plate	11503R09977-050	11503R09977-100	11503R09977-200
32	Inlet Air Distributor	11503R09978-050	11503R09978-100	11503R09978-150
33	Mixing Chamber	11503R09728-050	11503R09728-100	11503R09728-200
34	Combustion Blower	11J35R09582-001		
35	Flame Sensor [Qty. Req'd per Capacity]	11J38R06890-001		11J38R06890-001 [2]
36	Combustion Blower Gasket	11265R10026-005		
37	Flame Sensor Bracket [Qty. Req'd per Capacity]	N/A	11252R09716-000	11252R09716-000 [2]
38	Flame Sensor and Ignitor Bracket	11252R10181-050	N/A	
39	Burner Bracket, Vestibule Side [Qty. Req'd per Capacity]	11252R10045-000 [4]		
40	Burner Bracket, Burner Box Side [Qty. Req'd per Capacity]	11252R09669-000 [4]		
41	Burner Box Assembly ²	11502R10008-050	11502R10008-100	11502R10008-150
42	Standard Orifice	Natural Gas	11505R10091-05N	11505R10091-00N
		Propane (LP)	11505R10091-05P	11505R10091-00P
43	Flexible Gas Connector Hose	11J40R10129-001		
44	Gas Piping Assembly	11505R10337-001		11505R10337-002
45a, 45b	Gas Valve Bracket	N/A	11252R10012-000	
46	Gas Valve, Modulating	11J28R09581-001		
47	Trim Valve	N/A		
48	Fan Relay, 24/115V	11J10R03233-003	11J10R03233-001	11J10R03233-003
49	Fan Relay Bracket	11252R10013-000		
50	Contact, 24/115V	N/A		

Notes:

- 1- Includes Turn Cover and Turbulators.
- 2- Flame Sensor & Ignitor sold separately.

LEGEND: N/A - Not Applicable

HU SERIES 200-400 MBH REPLACEMENT PARTS

ITEM NO.	UNIT CAPACITY (MBH)	200	300	400
	ITEM DESCRIPTION	PART NO.		
1	Top Jacket Panel w/ Insulation	11251R09998-200	11251R09998-300	11251R09998-400
2a, 2b	Top Panel Block-Off	11507R10015-20T	11507R10015-30T	11507R10015-40T
3	Heat Exchanger Block-Off [Qty. Req'd per Capacity]	11507R10126-000	11507R10126-300 [2]	
4	Vestibule Panel/Heat Exchanger Assembly ¹	11501R09651-200	11501R09651-300	11501R09651-400
5	Left Side Jacket Panel w/ Insulation	11251R10009-200	11251R10009-300	11251R10009-400
6	High Limit Switch Bracket [Qty. Req'd per Capacity]	11252R09984-000 [2]	N/A	
	Left High Limit Switch Bracket	N/A	11252R09984-001	11252R09984-001
	Right High Limit Switch Bracket	N/A	11252R09984-002	11252R09984-000
7	High Limit Switch [Qty. Req'd per Capacity]	11J11R09594-001 [2]		
8	Heat Exchanger Baffle Assembly	N/A		
9	Inner Left Façade Panel (Black)	11251R09732-100	11251R09732-300	11251R09732-400
10	Louver Spring [Qty. Req'd per Capacity]	11J26R01960 [5]	11J26R01960 [7]	11J26R01960 [9]
11	Top Left Façade Panel	11251R09736-10T		
12	Bottom Left Façade Panel	11251R09736-10B		
13	Louvers [Qty. Req'd per Capacity]	11257R10063-200 [5]	11257R10063-200 [7]	11257R10063-200 [9]
14	Bottom Right Façade Panel	11251R09734-20B		
15	Top Right Façade Panel	11251R09734-20T		
16	Inner Right Façade Panel (Black)	11251R09731-200	11251R09731-300	11251R09731-400
17	Right Front Jacket Panel w/ Insulation	11251R10010-200	11251R10010-300	11251R10010-400
18	Bottom Jacket Panel w/ Insulation	11251R09999-200	11251R09999-300	11251R09999-400
19a, 19b	Bottom Panel Block-Off	11507R10015-20B	11507R10015-30B	11507R10015-40B
20	Burner Access Panel	11258R09997-200	11258R09997-300	11258R09997-400
21	Power Venter (Drafter) Access Panel	11258R09717-200	11258R09717-300	11258R09717-400
22	Partition Panel	11251R09689-200	11251R09689-300	11251R09689-400
23	Heat Exchanger Screen	11501R09987-200	11501R09987-300	11501R09987-400
24	Control Box Base (Wrapper)	11257R10336-002		
25	Control Box Access Panel	11251R09991-000		
26	Rear Jacket Panel	11251R09996-200	11251R09996-300	11251R09996-400
27	Manual Rollout Safety Switch	11J11R09595-001		
28	Manual Rollout Safety Switch Bracket	11252R09995-000		11252R09995-300
29	Spark Ignitor Bracket [Qty. Req'd per Capacity]	11252R09715-000 [2]		
30	Spark Ignitor [Qty. Req'd per Capacity]	11J38R06891-001 [2]		
31	Inlet Air Cover Plate	11503R09977-200	11503R09977-300	11503R09977-400
32	Inlet Air Distributor	11503R09978-200	11503R09978-300	11503R09978-400
33	Mixing Chamber	11503R09728-200	11503R09728-300	
34	Combustion Blower	11J35R09582-001	11J35R09582-002	
35	Flame Sensor [Qty. Req'd per Capacity]	11J38R06890-001 [2]		
36	Combustion Blower Gasket	11265R10026-005	11265R10026-018	
37	Flame Sensor Bracket [Qty. Req'd per Capacity]	11252R09716-000 [2]		
38	Flame Sensor and Ignitor Bracket	N/A		
39	Burner Bracket, Vestibule Side [Qty. Req'd per Capacity]	11252R10045-000 [4]		
40	Burner Bracket, Burner Box Side [Qty. Req'd per Capacity]	11252R09669-000 [4]		
41	Burner Box Assembly ²	11502R10008-200	11502R10008-300	11502R10008-400
42	Standard Orifice	Natural Gas	11505R10091-00N	11505R10091-30N
		Propane (LP)	11505R10091-00P	11505R10091-30P
43	Flexible Gas Connector Hose	11J40R10129-001	11J40R10134-001	11J40R10134-002
44	Gas Piping Assembly	11505R10337-002	11505R10337-003	11505R10337-004
45a, 45b	Gas Valve Bracket	11252R10012-000	11505R10160-300	
46	Gas Valve, Modulating	11J28R09581-001	11J28R10130-002	
47	Trim Valve	N/A	11J28R10243-000	
48	Fan Relay, 24/115V	11J10R03233-003	N/A	
49	Fan Relay Bracket	11252R10013-000	N/A	
50	Contact, 24/115V	N/A	11J10R06276-011	

Notes:

- 1- Includes Turn Cover and Turbulators.
- 2- Flame Sensor & Ignitor sold separately.

LEGEND: N/A - Not Applicable

HU SERIES 050-150 MBH REPLACEMENT PARTS

ITEM NO.	UNIT CAPACITY (MBH)	50	100	150
	ITEM DESCRIPTION	PART NO.		
51	Burner Mirror Bracket [Qty. Req'd per Capacity]	11252R10093-000 [2]	11252R10093-000	11252R10093-000 [2]
52	Burner Mirror	11257R10094-050	11257R10094-100	
53	Flue Limit Switch	11J11R09594-002		
54	Power Venter (Drafter) Assembly (includes gasket) ¹	11J35R09586-001		
55	Power Venter (Drafter) Gasket	11265R10026-010		
56	Power Venter (Drafter) Mounting Plate	11507R09994-050	11507R09994-100	11507R09994-200
57	Flue Collector Gasket	11265R10026-004		
58	Float Switch	11J11R09753-001		
59	Transformer, 50VA 115/24V ²	11J14R03245-012		
60	Ignition Control Board	11J28R09642-003		
61	Flue Collector (includes gaskets) ³	11507R09722-050	11507R09722-100	11507R09722-200
62	Turn Cover	11507R09718-050	11507R09718-100	11507R09718-200
63	Turn Cover Gasket	11265R10026-019	11265R10026-001	11265R10026-002
64	Turbulators [Qty. Req'd per Capacity]	11J37R09641-002 [13]	11J37R09641-002 [25]	
65	Main Control Board ⁴	11J11R09580-001		
66	Pressure Switch, Power Venter (Drafter) [label color]	11J11R09691-005 [gry]	11J11R09691-001 [grn]	11J11R09691-004 [yel]
67	Pressure Switch, Blocked Inlet [label color]	11J11R09692-001 [turquoise]		
68	LED Indicator, Red	11J11R09593-001		
69	LED Indicator, Orange	11J11R09593-002		
70	Pressure Transducer	11J11R10044-001		
71	Terminal Block Bracket	11507R10235-001	N/A	
72	Terminal Block	11J09R03265-001	N/A	
73	Inlet Air Collar Gasket	11265R10026-011		11265R10026-012
74	Inlet Air Collar	11507R10017-100		11507R10017-150
75	Filter Box ⁵	11507R10234-050	11507R09679-100	11507R09679-200
76	Filter	11J27R09592-001		11J27R09592-002
77	Filter Box Cover	N/A	11507R09698-100	11507R09698-200
78	Fan Blade [Qty. Req'd per Capacity]	11J34R06999-017 [2]	11J34R10162-000	11J34R10162-002 [2]
79	Fan Motor (Open Drip Proof) [Qty. Req'd per Capacity]	11J31R10194-001 [2]	11J31R09585-001	11J31R09585-001 [2]
80	OSHA Fan Guard (includes OSHA Guard Plate) [Qty. Req'd per Capacity]	11J32R04884 [2]	11J32R04840	11J32R04840 [2]
81	Fan/Guard/Motor Mount Hardware Kit [Qty. Req'd per Capacity]	11253R10334-001 [2]	11253R10334-002	11253R10334-002 [2]
N/S	Ignition Cable [Qty. Req'd per Capacity]	11J28R06971-002		11J28R06971-002 [2]
N/S	Hanging Bracket, Right	N/A		
N/S	Hanging Bracket, Left	N/A		
N/S	Condensate Trap Assembly	11264R10330-001		11264R10330-002
N/S	Flue Pipe Adaptor	N/A		
N/S	Flue Drainage Kit	N/A		
N/S	Pneumatic Tubing, 3/16" ID, 1 ft. length	11H07R01471-002		
N/S	Pneumatic Tubing, 1/8" ID, 1 ft. length	11H07R01471-003		
N/S	Pneumatic Tubing Fittings Kit	11262R10335		

Notes:

- 1- Flue Limit Switch sold separately (installs onto Power Venter).
- 2- See Transformers table for step down transformers used with Supply Voltage options 2-7.
- 3- When replacing the flue collector, make sure the flue collector box is sealed completely with factory supplied gasket.
- 4- Unit Serial No. is required to be listed on the purchase order; factory will program main control board based on unit serial card.
- 5- Filter Box Cover included with Filter Box for sizes 100-400 MBH, N/A for size 50 MBH.

LEGEND: N/S - Part Not Shown, N/A - Not Applicable

HU SERIES 200-400 MBH REPLACEMENT PARTS

ITEM NO.	UNIT CAPACITY (MBH)	200	300	400
	ITEM DESCRIPTION	PART NO.		
51	Burner Mirror Bracket [Qty. Req'd per Capacity]	11252R10093-000	11252R10093-000 [2]	
52	Burner Mirror	11257R10094-100	11257R10094-300	11257R10094-400
53	Flue Limit Switch	11J11R09594-002		
54	Power Venter (Drafter) Assembly (includes gasket) ¹	11J35R09586-001	11J35R09586-002	
55	Power Venter (Drafter) Gasket	11265R10026-010		
56	Power Venter (Drafter) Mounting Plate	11507R09994-200	11507R09994-300	11507R09994-400
57	Flue Collector Gasket	11265R10026-004	11265R10026-023	
58	Float Switch	11J11R09753-001		
59	Transformer, 50VA 115/24V ²	11J14R03245-012		
60	Ignition Control Board	11J28R09642-003		
61	Flue Collector (includes gaskets) ³	11507R09722-200	11507R09722-300	11507R09722-400
62	Turn Cover	11507R09718-200	11507R09718-300	11507R09718-400
63	Turn Cover Gasket	11265R10026-002	11265R10026-013	11265R10026-014
64	Turbulators [Qty. Req'd per Capacity]	11J37R09641-001 [38]	11J37R09641-001 [56]	11J37R09641-001 [77]
65	Main Control Board ⁴	11J11R09580-001		
66	Pressure Switch, Power Venter (Drafter) [label color]	11J11R09691-002 [wht]	11J11R09691-003 [red]	11J11R09691-002 [wht]
67	Pressure Switch, Blocked Inlet [label color]	11J11R09692-001 [turquoise]		
68	LED Indicator, Red	11J11R09593-001		
69	LED Indicator, Orange	11J11R09593-002		
70	Pressure Transducer	11J11R10044-001		
71	Terminal Block Bracket	N/A		
72	Terminal Block	N/A		
73	Inlet Air Collar Gasket	11265R10026-012	11265R10026-017	
74	Inlet Air Collar	11507R10017-200	Included with Filter Box	
75	Filter Box ⁵	11507R09679-200	11507R10146-300	
76	Filter	11J27R09592-002	11J27R09592-003	
77	Filter Box Cover	11507R09698-200	11507R10150-300	
78	Fan Blade [Qty. Req'd per Capacity]	11J34R10162-000 [2]	11J34R10162-001 [2]	11J34R10162-003 [2]
79	Fan Motor (Open Drip Proof) [Qty. Req'd per Capacity]	11J31R09585-001 [2]	11J31R09585-002 [2]	
80	OSHA Fan Guard (includes OSHA Guard Plate) [Qty. Req'd per Capacity]	11J32R04840 [2]		11J32R08289 [2]
81	Fan/Guard/Motor Mount Hardware Kit [Qty. Req'd per Capacity]	11253R10334-002 [2]		
N/S	Ignition Cable [Qty. Req'd per Capacity]	11J28R06971-002 [2]		
N/S	Hanging Bracket, Right	N/A	11252R10161-301	
N/S	Hanging Bracket, Left	N/A	11252R10161-302	
N/S	Condensate Trap Assembly	11264R10330-002		
N/S	Flue Pipe Adaptor	11J40R10104-006	11J40R10104-007	11J40R10133-007
N/S	Flue Drainage Kit	N/A		11257R10163-400
N/S	Pneumatic Tubing, 3/16" ID, 1 ft. length	11H07R01471-002		
N/S	Pneumatic Tubing, 1/8" ID, 1 ft. length	11H07R01471-003		
N/S	Pneumatic Tubing Fittings Kit	11262R10335		

Notes:

- 1- Flue Limit Switch sold separately (installs onto Power Venter).
- 2- See Transformers table for step down transformers used with Supply Voltage options 2-7.
- 3- When replacing the flue collector, make sure the flue collector box is sealed completely with factory supplied gasket.
- 4- Unit Serial No. is required to be listed on the purchase order; factory will program main control board based on unit serial card.
- 5- Filter Box Cover included with Filter Box for sizes 100-400 MBH, N/A for size 50 MBH.

LEGEND: N/S - Part Not Shown, N/A - Not Applicable

HU SERIES 050-400 MBH REPLACEMENT PARTS GAS CONVERSION KITS & TRANSFORMERS

GAS CONVERSION KITS

From Natural Gas (NG) to Propane (LP)		From Propane (LP) to Natural Gas (NG)	
Unit Size (MBH)	Part Number	Unit Size (MBH)	Part Number
050	11CVKTNTP-HU050	050	11CVKTPTN-HU050
100-200	11CVKTNTP-HU1-2	100-200	11CVKTPTN-HU1-2
300	11CVKTNTP-HU300	300	11CVKTPTN-HU300
400	11CVKTNTP-HU400	400	11CVKTPTN-HU400

TRANSFORMERS

UNIT SIZE (MBH)	050/100 ¹	150/200 ²	300 ³	400 ³
DESCRIPTION	PART NO.			
115/24, 50VA Transformer	11J14R03245-012			
208/115, Transformer	11J14R05241-005	11J14R02832-018	11J14R02832-016	11J14R02832-016
230/115, Transformer	11J14R02832-011	11J14R02832-018	11J14R02832-015	11J14R02832-015
460/115, Transformer	11J14R02832-011	11J14R02832-019	11J14R02832-015	11J14R02832-015
575/115, Transformer	11J14R05241-006	11J14R02832-020	11J14R02832-017	11J14R02832-017

Notes:

- 1- Unit Size 050/100 transformers are 1,500 VA
- 2- Unit Size 150/200 transformers are 3,000 VA
- 3- Unit Size 300 & 400 transformers are 5,000 VA

HU SERIES 050-400 MBH REPLACEMENT PARTS FIELD INSTALLED ACCESSORIES & MISC.

DESCRIPTION [ACCESSORY OPTION NO.]	PART NO.
Pressure Regulator (0.5 to 10 PSI) Natural Gas [A7-1/2-1]	11ASRA7-1/2-1
Pressure Regulator (10 to 20 PSI) Natural Gas [A7-3/8-1]	11ASRA7-3/8-1
Pressure Regulator (20 to 35 PSI) Natural Gas [A7-5/16-1]	11ASRA7-5/16-1
1-Stage Thermostat (Round) [G1]*	11ASRG1
1-Stage Thermostat (Round) with Guard Kit [G2]*	11ASRG2
1-Stage Thermostat w/ Fan Switch [G3]*	11ASRG3
2-Stage Thermostat, with Fan Switch [G5]*	11ASRG5
Universal Thermostat Guard/Locking Cover [G6]	11ASRG6
1-Stage Heating Only Thermostat [G9]*	11ASRG9
TH8321WF1001/u WiFi Thermostat [GW]*	11ASRGW
Condensate Neutralizer - Inline (050-200 MBH) [E9]	11ASRE9-1
Condensate Neutralizer - Inline (300-400 MBH) [E9]	11ASRE9-2
Condensate Neutralizer - Wall Mounted (050-200 MBH) [EW]	11ASREW-1
Condensate Neutralizer - Wall Mounted (300-400 MBH) [EW]	11ASREW-2
Stratification Sensor [H9]	11ASRH9
Condensate Pump [K8]	11ASRK8
Condensate Pump Shelf [K9]	11ASRK9
2" PVC Concentric Vent Kit (050-150 MBH) [Y2]	11ASRY2
3" PVC Concentric Vent Kit (200 MBH) [Y3]	11ASRY3
4" PVC Concentric Vent Kit (300-400 MBH) [Y4]	11ASRY4
Stainless Steel Wipes, 6 pack	11J37R10027-001
Touch Up Black Paint, Spray Can	11H01R10318-001
High Temp (RTV) Sealant - 2.8 oz. tube	11H03R03612-002
Outdoor Air Sensor (Gas Control options 1 & 2), See Fig. 9	11J11R09966-001
Room Sensor (Gas Control option 5), See Fig. 10	11J11R09974-001

* Thermostats are all Mercury-Free

Figure 9 - Outdoor Air Sensor



Figure 10 - Room Sensor



HVAC PRODUCTS

260 North Elm Street, Westfield, MA 01085

TEL: (413) 564-5540 * FAX: (413) 562-5311

www.sterlinghvac.com

 A MESTEK COMPANY